

|     |      |           |     |                      |         |     |      |
|-----|------|-----------|-----|----------------------|---------|-----|------|
| LOC | DIST | REVISIONS |     |                      |         |     |      |
| AJ  | 16   | P         | LTR | DESCRIPTION          | DATE    | DWN | APVD |
|     |      | L         |     | REV PER OU20-0563-00 | 19OCT00 | MO  | JL   |

1.85±0.25  
[.073±.010]

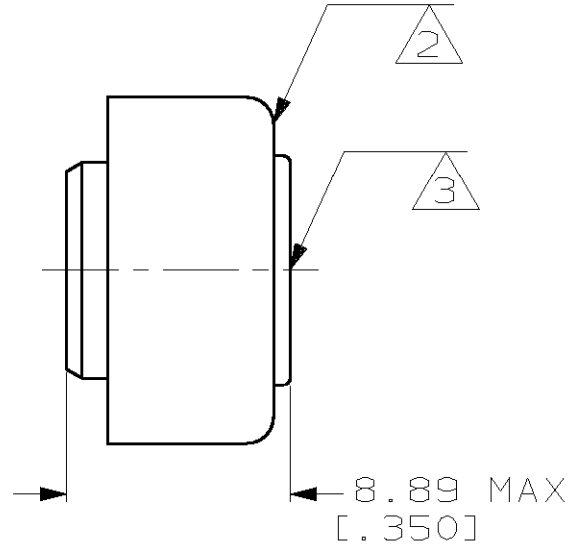
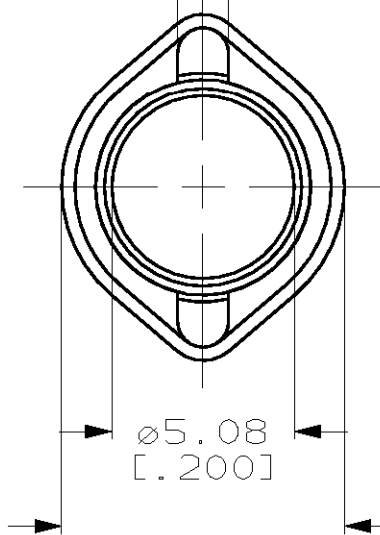

INSULATION SIZE: 3.68-4.67 DIA  
[.145-.184]

- 1 ZINC PLATE PER QQ-Z-325
- 2 COPPER PER QQ-C-576
- 3 BRASS PER ASTM-B-16
- 4 TIN PLATE PER MIL-T-10727

|        |             |
|--------|-------------|
| 4      | 2-327138-2  |
| 1      | 327138      |
| FINISH | PART NUMBER |

RELEASED FOR PUBLICATION

THIS DRAWING IS UNPUBLISHED.

BY AMP INCORPORATED. ALL RIGHTS RESERVED.

© COPYRIGHT 19

|  |                  |                |   |           |            |           |
|--|------------------|----------------|---|-----------|------------|-----------|
| DIMENSIONS:<br>mm                      | DWN              | J.L.GROFT      | MATERIAL                                      | SEE NOTES | FINISH     | SEE NOTES |
|  | CHK              | S.W.BURKHOLDER | AMP Incorporated<br>Harrisburg, PA 17105-3608 |           |            |           |
| TOLERANCES UNLESS OTHERWISE SPECIFIED: | APVD             | S.W.BURKHOLDER |   |           |            |           |
| 0 PLC ±-                               | PRODUCT SPEC     | -              | NAME  |           |            |           |
| 1 PLC ±-                               | APPLICATION SPEC | -              | FERRULE ASSEMBLY, TERMASHIELD                 |           |            |           |
| 2 PLC ±-                               | WEIGHT           | -              | SIZE  | CAGE CODE | DRAWING NO |           |
| 3 PLC ±.005                            |                  |                | A4  | 00779     | C-327138   |           |
| 4 PLC ±-                               |                  |                | CUSTOMER DRAWING                              |           |            |           |
| ANGLES ±-                              |                  |                | SCALE   | 4:1       | SHEET      | 1 OF 1    |
|  |                  |                |   |           | REV        | L         |